



DESCRIPTION

VALMATIC™ Single Sphere Flanged Rubber Flexible Joint (FSF) is designed with floating flanges for easy installation to the piping. It is used to absorb piping and pumping equipments from movement, isolate vibration, reduce system noise and compensate for misalignment. Because of the excellent moulding technique combined with tough chemical fibres, it may be used at a bursting pressure of over 850 PSI and within internal pressure of 225 PSI. The carcass is designed with special spherical type, and will not come in contact with the connecting bolt head even if it expands. This connector may be used with a sense of security even when subjected to high pressure.

VALMATIC™ Single Sphere Flanged Rubber Flexible Joint (FSF) is generally installed on both the delivery and the suction sides of the pumps. It neither needs gasket nor packing. It is applicable for water and warm water used in building equipment and general industrial plants, pump lines and turbine lines used for power generation plants, feed water and drainage lines for waterworks and sewerage, oil lines for industrial plants and shipbuilding yards, loading and unloading lines to and from ships for harbour facilities.

APPLICATION

Suitable for water, oil, gases and non-aggressive media.

SPECIFICATION

End Connection	- Flanged End to BS 10 Table E, others flange standard upon request
Working Pressure	- 15.5 Bar for DN 50 to DN 300 8.6 Bar for DN 350 to DN 600
Vacuum Rating	- 660 mm/Hg
Working Temperature	- Up to 80°C

MATERIALS

No.	Parts	Material
1.	Flange	Mild Steel with Galvanize
2.	Body (Outer Layer)	Neoprene Rubber
3.	Body (Inner Layer)	Neoprene Rubber
4.	Reinforcing Cord	Nylon Cord Fabric
5.	Reinforcing Ring	Carbon Steel

Others material are available upon request.

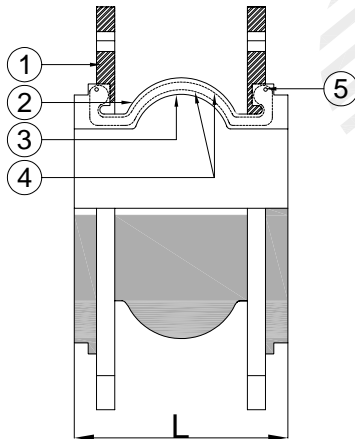

PRESSURE-TEMPERATURE RATINGS

Temperature	Ambient	40°C	50°C	60°C	70°C	80°C
Operating Pressure	15.5 Bar	14 Bar	12 Bar	10 Bar	8 Bar	6 Bar

The data given are only applicable for size DN 50 to DN 300. For DN 350 and above, please contact your local representative.

DIMENSIONS (mm) AND ALLOWABLE MOVEMENTS

Size (DN)	50	65	80	100	125	150	200	250	300	350	400	450	500	600
Natural Length –L	105	115	130	135	170	180	205	240	260	265	265	265	265	265
Axial Elongation	5	6	6	10	10	10	14	14	14	14	14	14	14	14
Axial Compression	8	12	12	18	18	18	25	25	25	25	25	25	25	25
Lateral Deflection	8	10	10	12	12	12	22	22	22	22	22	22	22	22
Angular Movement	15°	15°	15°	15°	15°	15°	15°	15°	15°	15°	15°	15°	15°	15°
Weight (Kg)	4.8	5.5	6.4	9.2	11	13	18.5	27	40	57	74	79	86	126

The specification is subject to change without further notice



VALMATIC ENGINEERING SDN BHD

35, Jalan Layang Layang 4, Puchong Jaya Industrial Park,
Bandar Puchong Jaya, 47100 Puchong,
Selangor, Malaysia

(369320 W)

Tel : 603-5882 6683
Fax : 603-5882 8366
Email : vmatic@pd.jaring.my
http : www.valmatic.com.my

OPERATING CONDITIONS

For Flexible Joint Type FSF (Single Sphere)
And Type FTF (Double Sphere)

Size : DN 50 to DN 300
Bursting Pressure : 58.6 Bar (580 P.S.I.)
Working Pressure : 15.5 Bar (225 P.S.I.)
Working Temperature : -10°C to 105°C

Size : DN 350 to DN 750
Bursting Pressure : 23.5 Bar (340 P.S.I.)
Working Pressure : 8.6 Bar (125 P.S.I.)
Working Temperature : 10°C to 105°C

CONTROL UNIT

Use of the Control Unit is recommended to protect the connectors for the following conditions :

- * Adequate piping support can be provided to counteract pressure forces.
- * Whenever transverse movement is expected that may exceed designed specification or the maximum pressure exceeds the designed pressure.
- * If there is a possibility that the rubber flexible joint will operate in a compression mode.

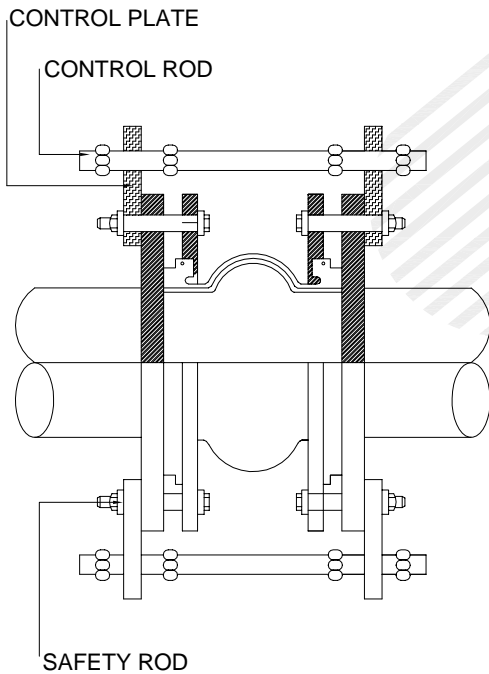

Flexible Joint Nominal Size		Operating Pressure			
inch	mm	100 PSI	150 PSI	200 PSI	225 PSI
1	25			Ⓢ	Ⓢ
1¼	32			Ⓢ	Ⓢ
1½	40			Ⓢ	Ⓢ
2	50			Ⓢ	Ⓢ
2½	65			Ⓢ	Ⓢ
3	80			Ⓢ	Ⓢ
4	100			Ⓢ	Ⓢ
5	125			Ⓢ	Ⓢ
6	150		Ⓢ	Ⓢ	Ⓢ
8	200	Ⓢ	Ⓢ	Ⓢ	Ⓢ
10	250	Ⓢ	Ⓢ	Ⓢ	Ⓢ
12	300	Ⓢ	Ⓢ	Ⓢ	Ⓢ
14	350	Ⓢ	Ⓢ		
16	400	Ⓢ			
18	450	Ⓢ			
20	500	Ⓢ			
22	550	Ⓢ			
24	600	Ⓢ			
28	700	Ⓢ			
30	750	Ⓢ			

Note :
Ⓢ = Use Control Rod

TYPE OF MOVEMENTS

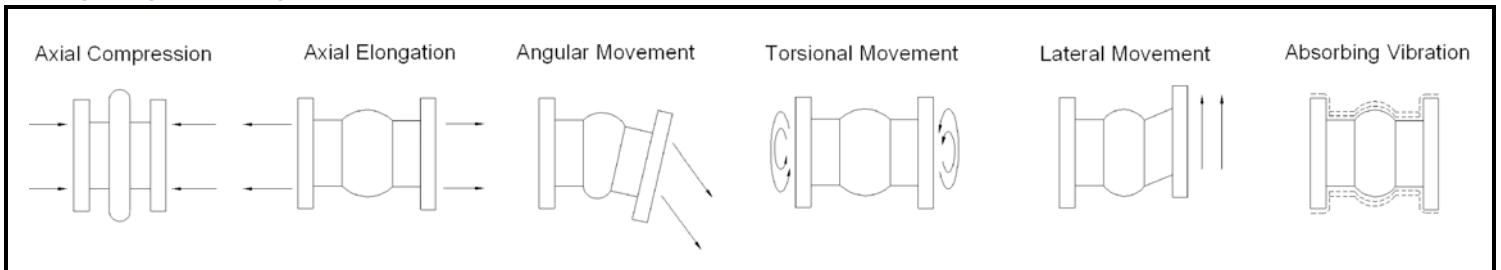

VALMATIC ENGINEERING SDN BHD

35, Jalan Layang Layang 4, Puchong Jaya Industrial Park, (369320 W)
Bandar Puchong Jaya, 47100 Puchong,
Selangor, Malaysia

Tel : 603-5882 6683
Fax : 603-5882 8366
Email : vmatic@pd.jaring.my
http : www.valmatic.com.my