



SPECIFICATION

Designed and Manufactured	API 602, ASME 16.34
Face to Face Dimension	ASME B16.10
Pressure Rating	Class 150, 300, 600, 800 or 1500
End Dimension	Threaded End, Socket Weld or Flanged End
Test and Inspection	API 598
Pressure - Temperature Rating	ASME B16.34

GATE VALVE FORGED STEEL / STAINLESS STEEL

MATERIALS

PARTS	FIG. 6R5	FIG. 6R6	FIG. 6R7
1. Body	A105	F304	F316
2. Seat	A276-410	SS304	SS316
3. Wedge	A182- F6A	F304	F316
4. Stem	A276- 410	304	316
5. Gasket	304 + Graphite	SS304 + Graphite	SS316 + Graphite
6. Gland Packing	Flexible Graphite	Graphite	Graphite
7. Bonnet	A105	F304	F316
8. Bonnet Bolt	A193- B7	A193- B8	A193- B8
9. Gland Bolt	A193- B7	A193- B8	A193- B8
10. Gland	A276- 410	SS304	SS316
11. Gland Flanged	Carbon Steel	F304	F304
12. Gland Nut	A194-2H	A194- 8	A194- 8
13. Sleeve Washer	A276- 410	A240- 410	A240- 410
14. Yoke Sleeve	410	A276- 410	A276- 410
15. Handwheel	Malleable Iron	Malleable Iron	Malleable Iron
16. Handwheel Nut	AISI 1025	AISI 1025	AISI 1025

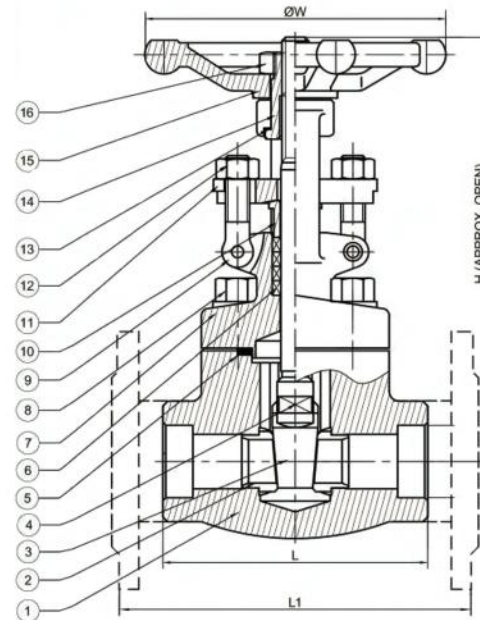

FIG 6R5S



FIG 6R5A

DIMENSIONS (mm)

Size (inch)	1/2	3/4	1	1½	2
L	79	92	111	120	140
L1(Class 150)	108	117	127	165	178
L1 (Class 300)	140	152	165	190	216
L1 (Class 600)	165	190	216	241	292
H	166	167	196	250	290
Ø W	100	100	120	160	180

*The specifications are subject to change without further notice