



APPLICATION

Suitable for water, oil, gases and others non-abrasive media
(Refer to corrosion resistance table for valve materials selection).

GATE VALVE SCREWED END BRASS / BRONZE / STAINLESS STEEL

SPECIFICATION

End Connection	Screwed End BSP Thread
Pressure Rating	PN20
Working Pressure	300 PSI Maximum
Working Temperature	Up to 120°C (Brass & Bronze) Up to 200°C (Stainless Steel)

MATERIALS

PARTS	FIG. 68S	FIG. 69S	FIG. 6N6 / 6N7
1. Body	Forged Brass	Bronze	SUS 304 / 316
2. Wedge	Brass	Bronze	SUS 304 / 316
3. Stem	Brass	D2R Brass	SUS 304 / 316
4. Bonnet Gasket	EPDM	EPDM	PTFE
5. Bonnet	Forged Brass	Bronze	SUS 304 / 316
6. Packing	EPDM	EPDM	PTFE
7. Gland Nut	Brass	Brass	SUS 304 / 316
8. Handwheel	Aluminium	Aluminium	Aluminium

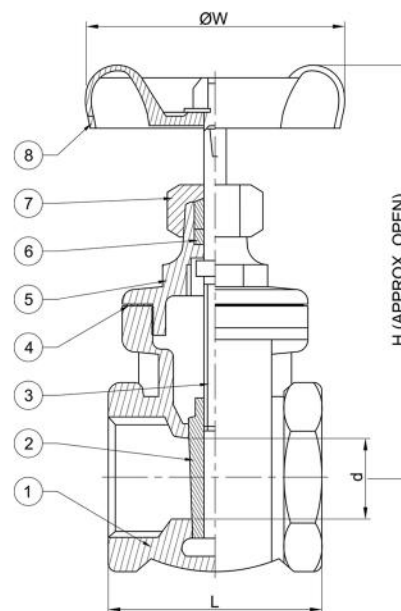

FIG 6

DIMENSIONS (mm)

Size	inch	1/2	3/4	1	1¼	1½	2	2½	3	4
	mm	15	20	25	32	40	50	65	80	100
L		34	48	53	58	66	73	80	85	97
H		64.5	73	77	81	91	94.5	114	124	148
d		13.5	19	24	31	38	49	59	70	94
ØW		54	58	64	72	78	88	110	118	138
Weight (Kg)		0.25	0.4	0.55	0.8	1.0	1.5	2.3	3.3	6.0

*The specifications are subject to change without further notice