



SPECIFICATION

Designed and Manufactured	API 600 and BS 1414
Face to Face Dimension	ASME B16.10
Pressure Rating	Class 150, 300, 600 and 900
Flange End Dimension	ASME B16.5
BW End Dimension	ASME B16.25
Test and Inspection	API 598
Pressure - Temperature Rating	ASME B16.34

GATE VALVE API 600 CARBON STEEL / STAINLESS STEEL

MATERIALS

PARTS	FIG. 6R2	FIG. 6R6	FIG. 6R7
1. Body	A216-WCB	A351-CF8	A351-CF8M
2. Seat Ring	A105 + STL	A351-CF8 + STL	A351-CF8M + STL
3. Wedge	A216-WCB + 13% Cr.	A351-CF8	A351-CF8M
4. Stem	A182-F6a	A182-F304	A182-F316
5. Bonnet Gasket	Graphite + Steel	PTFE	PTFE
6. Bonnet Nut	A194-2H	A194-8	A194-8M
7. Bonnet Bolt	A193-B7	A193-B8	A193-B8M
8. Bonnet	A216-WCB	A351-CF8	A351-CF8M
9. Bonnet Bush	A182-F6a	A351-CF8	A351-CF8M
10. Packing	Graphite	PTFE / Graphite	PTFE / Graphite
11. Gland	A182-F6a	A182-F304	A182-F316
12. Yoke	A216-WCB	A351-CF8	A351-CF8M
13. Yoke Sleeve	A439-D2	A439-D2	A439-D2
14. Handwheel	Nodular Iron	Nodular Iron	Nodular Iron

*Other Materials (example WCC, WC1, WC6, WC9, C5, LCB & etc.) are available upon request.

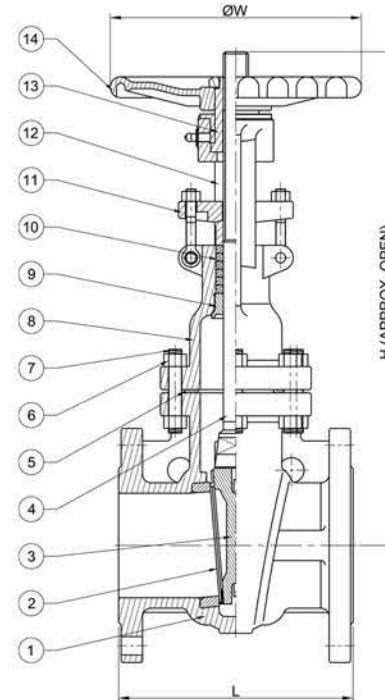

FIG 6R

DIMENSIONS (mm)

Size (inch)		2	2½	3	4	5	6	8	10	12	14	16	18	20	24
Class 150	L	178	190	203	229	254	267	292	330	356	381	406	432	457	508
	H	333	375	400	483	532	581	729	905	1060	1253	1390	1915	2122	2520
	ØW	200	200	220	250	280	300	350	400	450	460	460	500	600	600
	Weight (Kg)	19	25	33	49	62	77	123	188	288	385	500	601	764	1007
Class 300	L	216	241	283	305	381	403	419	457	502	762	838	914	991	1143
	H	345	446	458	510	722	651	1000	1249	1425	1585	1790	1960	2158	2575
	ØW	200	200	250	280	300	350	400	450	500	600	600	650	750	900
	Weight (Kg)	25	30	48	73	99	130	208	334	450	704	923	1131	1345	2122

*The specifications are subject to change without further notice