



APPLICATION

Suitable for water, steam, oil, gases and non-abrasive media (Refer to corrosion resistance table for valve materials selection).

SPECIFICATION

Face to Face Dimension According to EN 558-1 Series 1
End Connection Flanged End to DIN PN16 and PN40

MATERIALS

PARTS	FIG. 8S1	FIG. 8S2
1. Body	Cast Iron EN-GJL-250	Cast Steel GP240GH
2. Seat Ring	Stainless Steel X20Cr13	Stainless Steel X20Cr13
3. Disc	Stainless Steel X20Cr13	Stainless Steel X20Cr13
4. Bonnet Gasket	Graphite - CrNiSt	Graphite - CrNiSt
5. Packing	Graphite	Graphite
6. Gland	Cast Iron EN-GJL-250	Forged Steel C 22.8
7. Bonnet	Cast Iron EN-GJL-250	Cast Steel GP240GH
8. Stem	Stainless Steel X20Cr13	Stainless Steel X20Cr13
9. Handwheel	Cast Iron EN-GJL-250	Cast Steel GP240GH

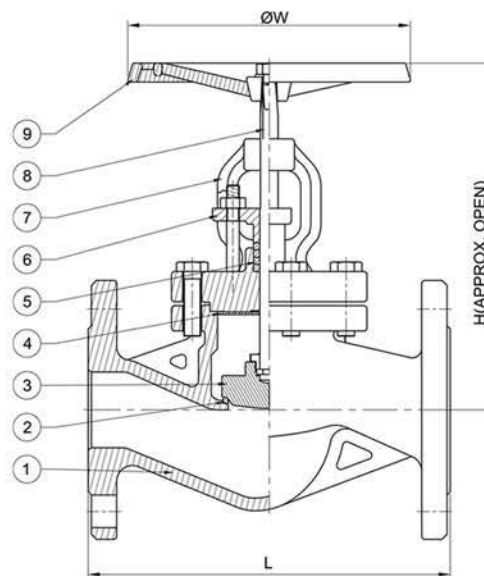

GLOBE VALVE S-PATTERN

CAST IRON / CARBON STEEL



FIG 8S1



FIG 8S2

PRESSURE-TEMPERATURE RATINGS ACC. DIN EN 1092-1/2

Material	Temperature										
	-10°C	20°C	100°C	120°C	150°C	200°C	250°C	300°C	350°C	400°C	450°C
PN16 - Cast Iron	16 Bar	16 Bar	16 Bar	16 Bar	14 Bar	13 Bar	11 Bar	10 Bar	-	-	-
PN40 - Cast Steel	40 Bar	40 Bar	40 Bar	40 Bar	37 Bar	35 Bar	32 Bar	28 Bar	24 Bar	21 Bar	18 bar

DIMENSIONS (mm)

Size (mm)	15	20	25	32	40	50	65	80	100	125	150	200	250	300
L	130	150	160	180	200	230	290	310	350	400	480	600	730	850
H - PN16	167	167	175	186	235	248	260	291	338	384	429	529	638	710
H - PN40	190	190	205	260	270	275	320	370	405	436	496	576	665	770
ØW - PN16	100	100	120	120	160	160	180	200	250	250	320	360	360	500
ØW - PN40	120	120	120	160	160	160	250	250	320	320	320	400	500	520
Weight (Kg) - PN16	3.3	3.9	5	6.6	8.4	12	17.3	22.7	35.8	52.8	74.2	126	200	315
Weight (Kg) - PN40	4.6	5.3	6	11	12.3	16	28	36	50	63	86	175	326	414

*The specifications are subject to change without further notice