



## APPLICATION

Suitable for water, oil, gases and others non-abrasive media  
(Refer to corrosion resistance table for valve materials selection).

## SPECIFICATION

End Connection	Screwed End BSPT Female Thread
Pressure Rating	16 Bar maximum
Working Temperature	Up to 80°C (Brass) Up to 180°C (Stainless Steel)

## MATERIALS

PARTS	FIG. 4SL8	FIG. 4SV
1. Body	Brass	St. Steel SS 316
2. Stem	Brass	St. Steel SS 316
3. Disc	NBR Rubber	PTFE
4. Disc Plate	Brass	St. Steel SS 316
5. Disc Retainer	Brass	St. Steel SS 316
6. Spring	Stainless Steel	St. Steel SS 316
7. Seat	Brass	St. Steel SS 316
8. Cap	Brass	St. Steel SS 316

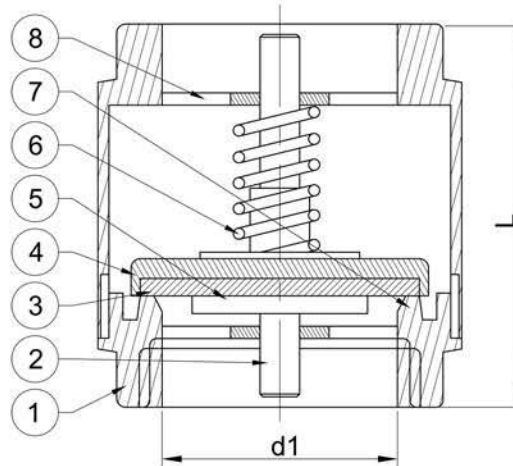

# CHECK VALVE SPRING LOADED

## BRASS / STAINLESS STEEL



**FIG 4SV**



**FIG 4SL**

## DIMENSIONS (mm)

Size	1/2	3/4	1	1¼	1½	2	2½	3	4
L (4SL)	48	48	54	54	68	77	93	102	115
d1	15	20	25	32	40	50	65	80	100
L (4SV)	61	-	-	-	-	-	-	-	-

\*The specifications are subject to change without further notice