



APPLICATION

Suitable for water, steam (*fig 217 only*), air (*fig 218 only*), oil, gases and non-abrasive media (Refer to corrosion resistance table for valve materials selection).

SPECIFICATION FIG 216 / 217

Design Reduced Bore
End Connection Screwed End BSP
Pressure Rating 1000 PSI W.O.G
Working Temperature Up to 180°C

FIG 218

Full Bore
Screwed End BSP
25 Bar maximum
Up to 120°C

MATERIALS

PARTS	FIG. 216 / 217	FIG. 218
1. Body	Stainless Steel SUS 304 / 316	Nickel Plated Brass
2. Seat	PTFE	PTFE
3. Ball	Stainless Steel SUS 304 / 316	Chrome Plated Brass
4. Stem	Stainless Steel SUS 304 / 316	Brass
5. Stem Packing	PTFE	PTFE
6. Lever	Stainless Steel SUS 304 / 316	Aluminium
7. Lever Cover	Plastic	Plastic

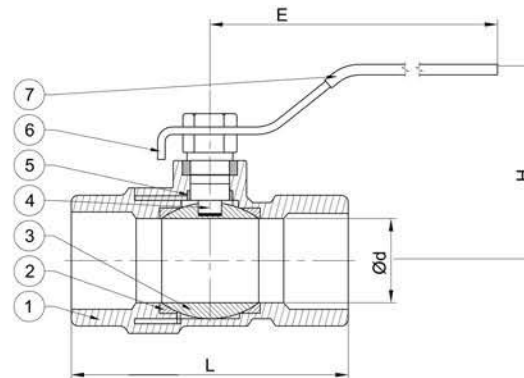

BALL VALVE ONE PIECE BODY STAINLESS STEEL

BALL VALVE TWO PIECE BODY BRASS



FIG 217

DIMENSIONS (mm)

Size	inch mm	1/4	3/8	1/2	3/4	1	1¼	1½	2	2½	3	4
		8	10	15	20	25	32	40	50	65	80	100
Stainless Steel	L	39	44	56.5	58	71	78	83	100	-	-	-
	d	5	7	9.2	12.5	15	20	24.5	32	-	-	-
	H	35	37	43.5	47	50	57	69	74.5	-	-	-
	E	64	70	90	90	103	103	127	127	-	-	-
	Weight (Kg)	0.07	0.1	0.16	0.25	0.43	0.7	0.83	1.5	-	-	-
Brass	L	-	40.5	48.5	54	64.5	76	88	100	132	152	178
	d	-	10	14.8	19	24	30.2	37	47	62	74	90
	H	-	39.4	47.5	51	61	72.5	77	86	115.5	124	135.5
	E	-	85	98	98	125	142	142	165	225	225	225
	Weight (Kg)	-	0.2	0.26	0.44	0.7	1.08	1.62	2.7	3.6	5.7	10

*The specifications are subject to change without further notice



FIG 218