



APPLICATION

Suitable for water, oil and others non-abrasive media
(Refer to corrosion resistance table for valve materials selection).

SPECIFICATION

End Connection	Flanged End to DIN 2526 PN16
Pressure Rating	PN16
Working Temperature	Up to 90°C
Test Pressure (Hydrostatic)	Body- 24 Bar Seat- 17.6 Bar

FOOT VALVE CAST IRON

MATERIALS

PARTS	FIG. 151
1. Body	Cast Iron EN-GJL-250
2. Guide	Cast Iron EN-GJL-250
3. Bushing	Brass
4. Spring	Stainless Steel
5. Stem	Stainless Steel
6. Disc	Cast Iron EN-GJL-250
7. Disc Ring	NBR
8. Screen	Stainless Steel 304

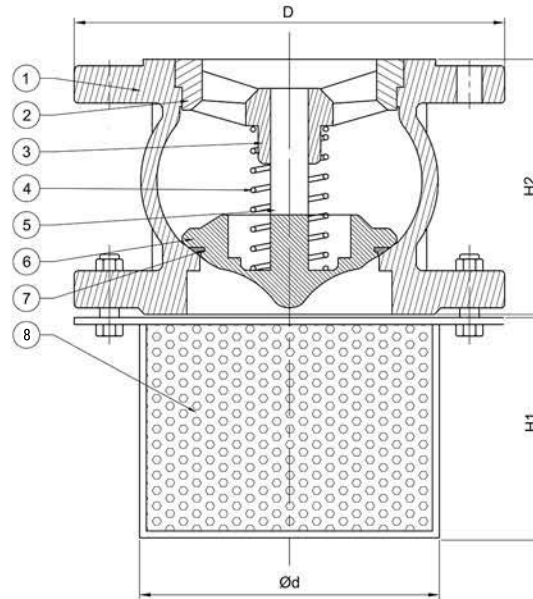

FIG 151

DIMENSIONS (mm)

Size (mm)	50	65	80	100	125	150	200	250
D	165	185	200	220	250	285	340	405
Ød	111	131	148	168	198	222	278	329
H1	80	100	120	150	175	200	250	300
H2	100	120	140	170	200	230	300	370

*The specifications are subject to change without further notice