



FOOT VALVE STAINLESS STEEL

APPLICATION

Suitable for water, oil and others non-abrasive media
(Refer to corrosion resistance table for valve materials selection).

SPECIFICATION

End Connection	Flanged End to ANSI 150
Pressure Rating	ANSI 150
Working Temperature	Up to 180°C
Test Pressure (Hydrostatic)	Body - 24 Bar Seat - 17.6 Bar

MATERIALS

PARTS	FIG. 156
1. Body	CF8/CF8M
2. Disc	CF8/CF8M
3. Stud	A93-2H
4. Nut	A194-9
5. Seal	PTFE
6. Seat Ring	SS304/SS316
7. Bonnet	CF8/CF8M

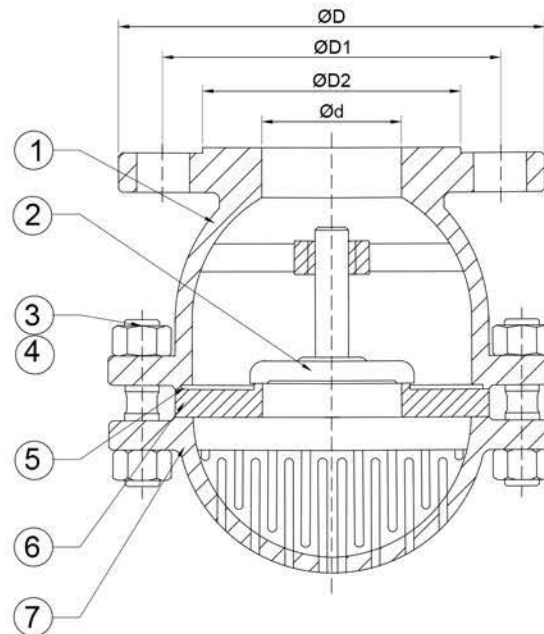

FIG 156

DIMENSIONS (mm)

Size (mm)	50	65	80	100	125	150	200	250
ØD	152	178	191	229	254	279	345	405
ØD1	120.5	139.5	152.4	190.5	215.9	241.3	298.5	362
ØD2	92.1	105	127	157.2	185.7	215.9	269.9	323.8
ød	50	65	80	100	125	150	200	250

*The specifications are subject to change without further notice