



## APPLICATION

Suitable for water, oil, gasses and others non-abrasive media.

## SPECIFICATION

End Connection	Flanged End to PN16, ANSI 150, others flange standard upon request
Working Pressure	15.5 Bar for DN 50 to DN 300 8.6 Bar for DN 350 to DN 600
Vacuum Rating	660 mm/Hg
Working Temperature	Up to 80°C

# RUBBER FLEXIBLE JOINT SINGLE SPHERE FLANGED

## MATERIALS

PARTS	FIG. 51S
1. Flange	Mild Steel with Galvanize
2. Body (Outer Layer)	EPDM Rubber / Neoprene
3. Body (Inner Layer)	EPDM Rubber / Neoprene
4. Reinforcing Cord	Nylon Cord Fabric
5. Reinforcing Ring	Carbon Steel

\*Others material are available upon request.

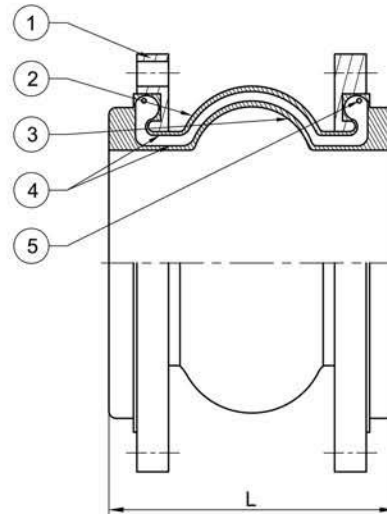

**FIG 51S**

## PRESSURE-TEMPERATURE RATINGS

Temperature	Ambient	40°C	50°C	60°C	70°C	80°C
Operating Pressure	15.5 Bar	14 Bar	12 Bar	10 Bar	8 Bar	6 Bar

\*The data given are only applicable for size DN 50 to DN 300. For DN 350 and above, please contact your local representative.

## DIMENSIONS (mm) AND ALLOWABLE MOVEMENTS

Size (mm)	50	65	80	100	125	150	200	250	300	350	400	450	500	600
Natural Length-L	152	152	152	152	152	152	152	203	203	203	203	203	203	254
Axial Elongation	9	9	9	13	13	13	13	16	16	16	16	16	16	16
Axial Compression	13	13	13	19	19	19	19	25	25	25	25	25	25	25
Lateral Deflection	13	13	13	13	13	13	13	19	19	19	19	19	19	19
Angular Movement	15°	15°	15°	15°	15°	15°	15°	15°	15°	15°	15°	15°	15°	15°
Weight (Kg)	4.8	5.5	6.4	9.2	13	13	18.5	27	40	57	74	79	86	126

\*The specifications are subject to change without further notice